



imes-icore[®]
Dental & Medical Solutions



CORiTEC[®] one | one⁺

The CORiTEC[®] one series

WHAT ARE THE DIFFERENCES?

	CORiTEC one	CORiTEC one ⁺
Number of axes	4	5
Number of tool positions	6	10
Spindle power/rpm	860 watt / 100.000 rpm	
Quick-Clamping-System (manuel)		✓
98 mm blank processing	-	✓
Integrated coolant tank		✓
C-Clamp processing	-	Optional
98 mm blank holder	-	Included
Universal fixture for glass ceramic and premilled abutments	Included	Included
6-fold glass ceramic holder (for 98 mm blank holder)	-	Included



VERSATILE IN
all cases

imes-icore[®] chairside/practice lab

WORKFLOW AND COMPONENTS

IOS

CORITEC
i^{one} scan

Align iTero

GC Aadvia IOS 200

Carestream CS 3600

Medit i500

Shining 3D Aoralscan

3DISC Heron

Dentsply Sirona

Primescan

... and other
scanners

CAD

exocad
ChairsideCAD



CAM

iCAM *one*

iCAM *one*⁺



CORITEC[®]
one



CORITEC[®]
one⁺



Materials

Pre-sintered ZrO₂

Full dense sintered ZrO₂

Premilled Ti-Abutment

Wax

Premilled

CoCr-Abutment

Glass ceramic

Lithium disilicate

Lithium silicate

Hybrid ceramic

Composite

PMMA / PEEK

Tools

Milling and
grinding tools



Result

Crown/Bridge
(up to 3 units)



Inlay, Onlay,
Veneer



Hybrid
Abutment



Abutment



Additional for CORITEC *one*⁺

Splint



Surgical
guide



Full Denture



Bridge larger
3 units

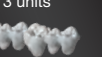

Model casting



Model



Bridge



Telescopic
technology



CORiTEC[®] one

THE INTELLIGENT PRACTICE LAB SOLUTION

The new CORiTEC one machine is a perfect choice for processing all common designed CAD/CAM blocks. With the new extremely stable axis kinematics, the machine is also capable to mill prefabricated abutments.

The high-quality cast aluminum construction ensures maximum stability with a minimum footprint. An integrated powerful PC along with 10'1" HD touch screen display supports a comfortable and ergonomic operation. A single block holder with six tool positions and smart tool replacement function guarantee an economical, safe and fast machining process with the highest quality. CORiTEC one is ideally suited every dental office, practice laboratory and clinic in combination with all open scanners. As a supplemental system for the specialized processing of glass ceramic, zirconia, composite and premilled abutment the CORiTEC one leaves nothing to be desired either for clinics, laboratories or milling centers.

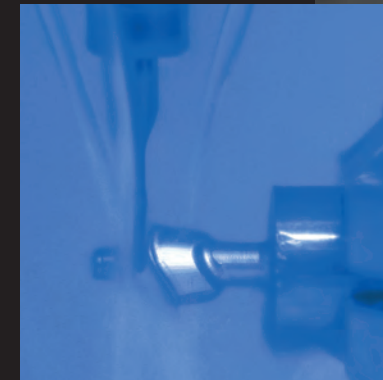
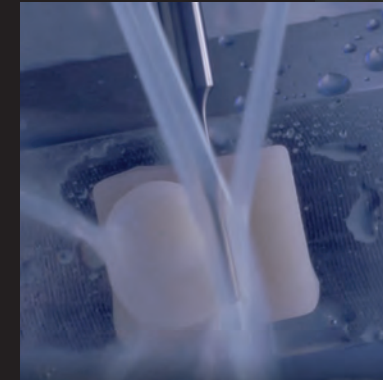

approx. 16.6 inch / 42.2 cm



- WET
- DRY
- 4 AX
- 3 mm
6x
- Temperature control icon
- Touch screen icon
- Block holder icon
- Person icon
- Base icon

CORiTEC[®] one

HIGHLIGHTS

- Novel closed mono-block cast body for stability and precision
- Self-sufficient operation without external required compressed air
- Optimized for the integrated CAD/CAM workflow with exocad
- Very fast grinding and milling process
- Short amortization period
- High precision due to integrated temperature compensation
- Machining of all common material blocks and prefabricated abutments
- Minimal footprint
- No external PC required
- Integrated HD camera for online monitoring
- Auto-calibration
- Automatic cleaning function
- Wet and dry machining option



PMMA	WAX	1-fold holder (blocks/premilled abutments)	Crown, Bridge	Inlay, Onlay Veneer	Bridge larger 3 units	Splint
Zr Pre-sintered	Zr Full dense sintered		Full Denture	Model	Surgical guide	Model casting
PEEK	COMPOSITE		Bridge	Telescopic technology	Abutment	Hybrid Abutment
Glass ceramics	SINT					
Premilled CoCr- Abutment	Premilled Ti- Abutment					

CORiTEC® one+

THE EXTENDED CHAIRSIDE MILLING SYSTEM

The CORiTEC one+ is the high-end model in the chairside area. Due to the 5-axis simultaneous technology, the C-Clamp holder and the blank holder can be integrated in addition to the single universal holder. This generates new application possibilities and more flexibility for creating the expected tooth restoration. The compact and stable basic design of the machine enables precise work in block and blank shapes. Look and see for yourself and be convinced about the functionality and performance of CORiTEC one+, which exceeds all expectations of the dentist.

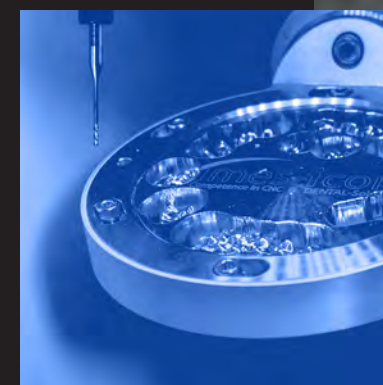

- WET
- DRY
- 5 AX
- 3 mm
10x
- Temperature control
- Touchscreen
- USB
- Operator interface
- Workpiece

ERGONOMIC HANDLING
Simple graphical touchscreen operation

EASY CLEANING
Fully coated enclosed wet cell

HALF-OPEN BLANK HOLDER "C-CLAMP" (OPTIONAL)

POWERFUL PERFORMANCE
High end spindle for milling and grinding work up to 100.000 rpm

INTEGRATED TEMPERATURE COMPENSATION

INTEGRATED WATER TANK AND FILTRATION



CORiTEC[®] one+

HIGHLIGHTS

- Novel, closed mono-block cast body for highest stability and precision
- No external PC required
- Half-open blank holder "C-Clamp" (optional)
- High precision due to integrated temperature compensation
- Self-sufficient operation without external required compressed air
- Short amortization period
- Minimal footprint
- Auto-calibration
- Integrated HD camera for online monitoring
- Automated cleaning function
- Wet and dry processing option

PMMA	WAX	1-fold holder (blocks/premilled Abutments)	Standard	Dentures	C-Clamp	Crown, Bridge	Inlay, Onlay Veneer	Bridge larger 3 units	Splint
Zr Pre-sintered	Zr Full dense sintered								
PEEK	COMPOSITE	Block	Premilled Abutment	Quick-Clamping-System (manuel)		Full Denture	Model	Surgical guide	Model casting
Glass ceramics	SINT								
Premilled CoCr-Abutment	Premilled Ti-Abutment					Bridge	Telescopic technology	Abutment	Hybrid Abutment

Holders



1-FOLD UNIVERSAL ADAPTER

- Base unit for processing of glass ceramics blocks and different abutment systems
- Turn-milling processing possible

C-CLAMP HOLDER

- Half-open blank holder
- Enables 5-axis machining up to 90 degrees axis adjustment
- Complex end face machining possible

BLANK HOLDER

- Closed blank holder for high stability
- Processing of all common chairside materials in blank shape

6-FOLD HOLDER

- Processing of up to 6 blocks at once possible
- Processing of all common chairside materials (e.g., glass ceramics & lithium disilicate)

CORiTEC® preMill Abutment

CUSTOMIZED SOLUTION WITH ADDED VALUE AND GROWTH FOR LABORATORIES AND PRACTICES

The CORiTEC preMills are supplied with abutment screw, compatible libraries, modules and holders. This enables dental technicians and dentists in the laboratory and dental practice to manufacture customized one-piece abutments made of titanium with full control over quality and time – fully in accordance with FDA regulations.

ADVANTAGES

- Follows the natural morphology of the soft tissue
- Supports the gingiva and creates a root-shaped emergence
- Allows angulation for alignment of the prosthetic crown
- Adapts to the anatomical shape of the crown, providing perfect support and a larger bonding surface
- Allows a natural transition from the implant to the prosthetic crown

FEATURES

- **Self-locking screws** prevent loosening from the module
- **Modular design of the holder** (easy assembly, cleaning and easy replacement)
- **One-tool concept** simplifies mounting of the holder, modules and CORiTEC preMills by using a Torx 20 tool
- **High degree of design freedom** due to minimal gingival height and improved library geometry
- **Perfect implant emergence profile**, as no widening of the emergence profile above the implant diameter is required
- **Smooth transition area** significantly reduces manual reworking
- **Perfect CAM interaction** due to automatic nesting by implementation of metadata



MORE DESIGN FREEDOM FOR MORE MAXIMUM FLEXIBILITY

Materials

priti® MULTIDISC (ZIRCONIUM DIOXIDE)

High-end zirconium dioxide for the highest mechanical and aesthetic demands. Indications for use include up to 16-unit bridges, limited to a maximum of 3-unit bridges for High Translucent.

A large selection of colors and heights is available.

	Translucency	Strength
Multi Translucent PLUS	49-45 %	800 – 1150 MPa
Multi Translucent	49-40 %	800 – 1150 MPa
High Translucent	49 %	> 650 MPa
Extra Translucent	45 %	> 1150 MPa
Translucent	40 %	> 1150 MPa
Opaque	35 %	> 1150 MPa



CORTEC TEMP PMMA DISC

An excellently processable material suitable for long-term provisionals with a wear duration of up to three years, including intrinsic color gradients.

Available in 8 Vita colors in 16 mm and 20 mm.



CORTEC GUM PMMA DISC

For gingiva replacement, available in 25 mm.



CORTEC SPLINT COMFORT POLYMERS

Extremely comfortable and biocompatible material for the manufacturing of therapeutic splints such as occlusal or stabilization splints. Becomes more flexible at mouth temperature for maximum wearing comfort.

Available in 16 mm and 20 mm.



CORTEC SPLINT BASIC POLYMERS

Crystal-clear material for the manufacturing of therapeutic splints and surgical guides.

Available in 16 mm and 20 mm.

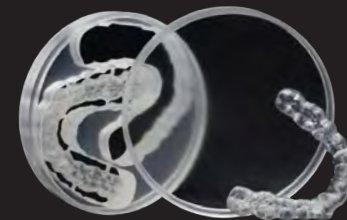

Materials

VITA ENAMIC®

VITA ENAMIC® is a unique tooth-colored hybrid ceramic with a dual ceramic-polymer network structure. This special composition combines high resilience with great elasticity, allowing for straightforward, efficient, and precise manufacturing of dental restorations.

- Gentle and substance-preserving preparation
- Wide range of indications from table tops to non-prep veneers
- Resilience and elasticity nearly identical to the natural counterpart
- Highly aesthetic with integrated natural color gradient
- Antagonist-friendly and enamel-like
- Particularly suitable for use on implants



Initial LiSi Block from GC

The Initial LiSi Block is a fully crystallized lithium disilicate block that possesses optimal physical properties without the need for a firing process.

- No firing process required
- High abrasion resistance
- Durable aesthetics and precise margins
- Natural opalescence



VITABLOCS® TriLuxe forte

Polychrome, tooth-colored feldspar blanks with an integrated color gradient for reproducing the natural color spectrum. VITABLOCS® TriLuxe forte is the best solution for aesthetic reconstructions in smaller defects and highly aesthetic restorations in the visible area.

- Durable material with excellent long-term clinical performance
- Brilliant color and light play
- Time-saving CAM production and efficient finalization through polishing without any firing guidance



CERASMART270 from GC:

CERASMART270 is an aesthetic hybrid block designed for fast and long-lasting clinical success. It is the optimal block for a wide range of applications, whether for a quick onlay or a challenging abrasion case.

- Fast and efficient milling process
- Improved flexural strength and high fracture resistance
- Extremely precise margins for seamless transitions
- Excellent polishability and gloss retention
- Optimal fluorescence and translucency



PRECISE MILLING TOOLS for Chairside Workflow

Glass ceramic	Feldspar	Lithium disilicate	
Lithium silicate	Hybrid ceramics	Composite	Full dense sintered zirconia

T21 - 2.5 | 3.0 mm
radius grinding tool
(diamond)



Art. No. 530005 2503

T22 - 1.0 | 3.0 mm
radius grinding tool
(diamond)



Art. No. 530005 1003

T23 - 0.6 | 3.0 mm
radius grinding tool
(conical, diamond)



Art. No. 530005 0603

T24 - 1.5 | 3.0 mm
radius grinding tool
(diamond)



Art. No. 530005 1503

PMMA	Wax
------	-----

T11 - 2.5 | 3.0 mm
radius milling tool
(single blade, slide coated)



Art. No. 530004 2503

T12 - 1.0 | 3.0 mm
radius milling tool
(single blade, slide coated)



Art. No. 530004 1003

T15 - 0.6 | 3.0 mm
radius milling tool
(conical)



Art. No. 530016 0603

Pre-sintered Zirconia

T13 - 2.5 | 3.0 mm
radius milling tool
(diamond coated)



Art. No. 530013 2503

T14 - 1.0 | 3.0 mm
radius milling tool



Art. No. 530013 1003

T15 - 0.6 | 3.0 mm
radius milling tool
(conical)



Art. No. 530016 0603

Premilled Abutment	CoCr
--------------------	------

T7 - 2.0 | 3.0 mm
radius milling tool
(l = 12 mm)



Art. No. 530029 2003

T8 - 1.5 | 3.0 mm
radius milling tool
(l = 12 mm), universal



Art. No. 530029 1503

T9 - 1.0 | 3.0 mm
radius milling tool
(l = 9 mm)



Art. No. 530029 1003

T58 - 2.0 | 3.0 mm
highspeed milling tool
(l = 12 mm)



Art. No. 530031 2003

Premilled Abutment	Titan
--------------------	-------

T2 - 2.0 | 3.0 mm
radius milling tool
(l = 12 mm)



Art. No. 530029 2003

T3 - 1.5 | 3.0 mm
radius milling tool
(l = 12 mm), universal



Art. No. 530029 1503

T4 - 1.0 | 3.0 mm
radius milling tool
(l = 9 mm)



Art. No. 530029 1003

T59 - 2.0 | 3.0 mm
highspeed milling tool
(l = 12 mm)



Art. No. 530031 2003

ChairsideCAD software

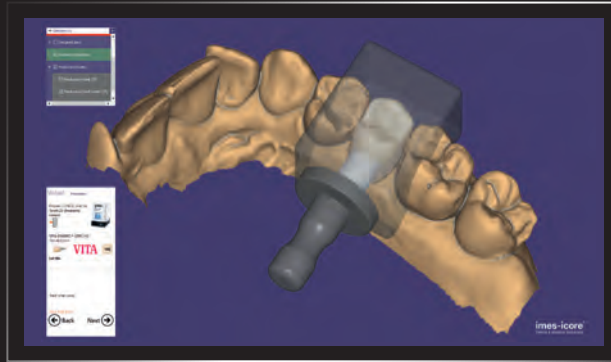

With the help of exocad ChairsideCAD, crowns, inlays, onlays, veneers and small bridges can be designed and manufactured directly at the treatment center in a very innovative and fast workflow. Using the integrated In-CAD Nesting module, the designed jobs can be placed directly in the block for calculating and milling by the machine.

Add-on modules

MANY EXTENDED POSSIBILITIES

TrueSmile module

Realistic visualization of the dental restorations

Auto articulator module

Simulation of jaw movements for precise dynamic occlusion

Provisional module

Design of temporary egg shells based on preoperative scans

In-CAD nesting module

Positioning of restorations in milling blanks

Smile creator

Predictable planning and preview of esthetic restorations

Implant module

Design of abutments and directly screw-retained crowns and bridges

Your benefits

Increase patient satisfaction and improve efficiency

ChairsideCAD allows you to perform restorative dental procedures during a single visit dentistry.

Create esthetic and functional restorations and enjoy usability

ChairsideCAD is easy to use and guides you step by step through the process. Therefore, no extensive training is necessary.

Effortless collaboration with partners

ChairsideCAD facilitates communication with dental laboratories and production centers for better and more predictable results.

Process an unlimited number of cases

ChairsideCAD has no hidden costs or click charges.

Benefit from our proven software platform

exocad software has been an integral part of dental laboratories for 10 years.

Maintain your flexibility

ChairsideCAD supports virtually any modification you make to your workflow, equipment or services.

Expand your range of services

ChairsideCAD can be extended with various add-on modules according to your desires.

imes-icore Chairside Nesting+

SMART HIGH END SOLUTION

Experience multifunctional possibilities with 5-axis machining. The revolutionary Chairside Nesting+ allows the processing of indications without limitations due to the automated data transfer and the intelligent blank management. This makes workflows a secondary matter and puts the work on the patient in the focus.

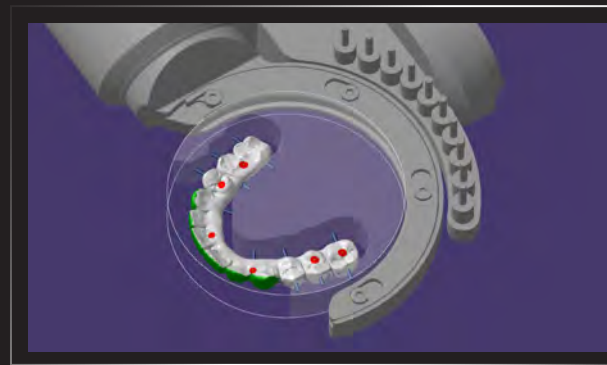

Auto-calibration

FAST, PRECISE, COST-EFFICIENT

Auto-calibration allows both dentist and dental technician a quick and easy handling to ensure lasting precision without compromise.

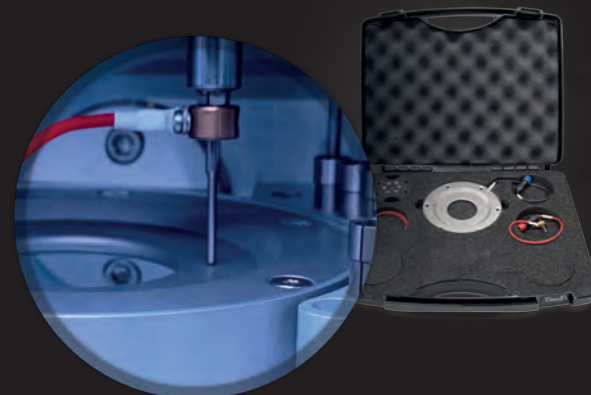

CORiTEC® SmartControl™

SMART CONTROL OF MACHINE SOFTWARE

SmartControl™: one touch ahead!

The newly developed control software SmartControl™ enables absolutely intuitive operation of our milling machines. From selecting the job to milling or querying the machine status; the self-explanatory and optimized handling makes it possible to start operating the machine in the shortest possible time. Starting a milling process requires only two clicks – you benefit from the smart time savings for your workflow!

FEATURES

- Modern design and simple touch operation
- Intelligent selection of milling jobs
- Easy tool and material loading
- Auto-calibration of the machine
- Wizard guided cleaning and maintenance
- Connection to the Dental Smart Market (DSM)
- Multilingual program interface
- Automatic update function

Optimized for touchscreen operation



Automated transfer of information from the CAM software

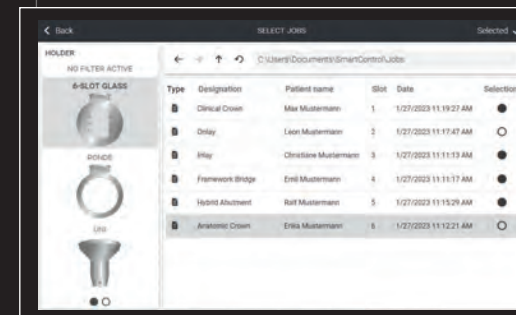

Ideal tool management



Intraoral scanners

COMPATIBLE WITH
exocad

To achieve a fully integrated workflow, the new CORTEC one machine system can be combined with all open intraoral scanners.

Producer	Scanner model	Producer	Scanner model
imes-icore	CORTEC one scan	Medit	i500/i700
Align	iTero	Shining 3D	Aoralscan
GC	Aadva IOS 200	3DISC	Heron
Carestream	CS 3600 / CS 3700	Dentsply Sirona	Primescan



Can be combined with all open
INTRAORAL SCANNERS

Suction unit

iVAC silent

The unit is equipped with a teflon filter cartridge, automatic filter cleaning and a dust drawer. With the suction power of 160m³/hr the iVAC silent is perfectly suited for your CORTEC one and one+. The unit can be stored on the optional machine table.

	iVAC silent
Airflow	160 m ³ /hr
Power	490 W
Filter system	Teflon filter cartridge, automatic cleaning feature
Filter volume	8 liters/30.28 gpm (dust drawer)
Width x depth x height	9.6 x 19.6 x 17.3 inch / 245 x 500 x 440 mm
Supply voltage	230 V
Special features	Suitable for machine tables T0, T1 and T2, quiet running, very compact, self-cleaning by vibration

Machine table



Machine table T0

The T0 offers stability and appealing optics. Steady castors guarantee the secure mobility of your machine. The dimensions of 422 x 540 x 900 mm / 16.6 x 21.3 x 35.4 inch (W x D x H) provide sufficient utility space. Focusing on space-saving the T0 is equipped with drawers, cable bushing and storage room for the respective suction unit.



wet milling

...IN THE
CHAIRSIDE AREA

Both systems can be easily combined with the intraoral scanner (i-one Scan) from imes-icore. The perfect combination of the workflow with the exocad software guarantees the best user-friendly, precise and optimized systems for the chairside area.

dry milling

UNSURPASSED
FLEXIBILITY...

Both CORTEC *one*, as well as *one+* offer an unsurpassed range of indications with the possibility of wet and dry processing. Regardless of the chosen method, the stable core of the system offers the highest quality restoration.



Dimensions

CORiTEC® one | one+

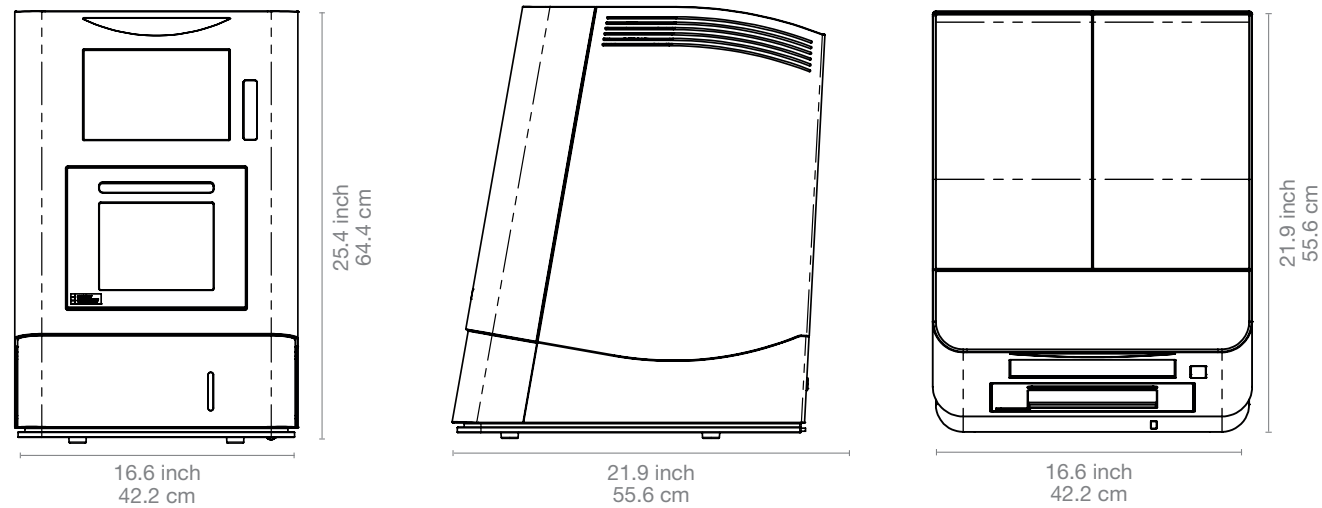

Machine table T0

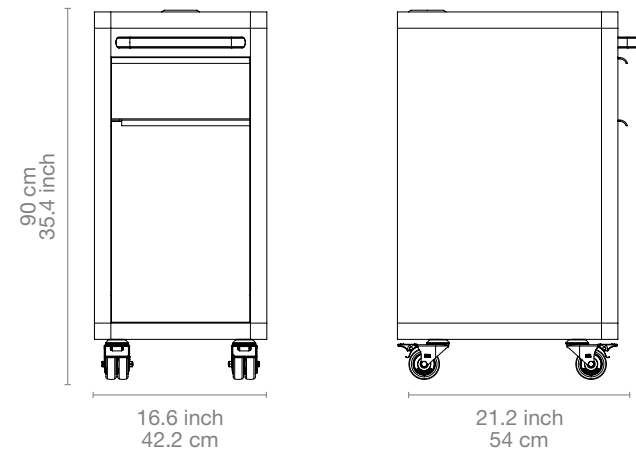

In numbers

Mechanics/electronics	one®	one+
Number of axes / operation type	4 axes simultaneous processing	5 axes simultaneous processing
Angle of attack	± 180°	B-axis 130°
Angle of rotation	A-axis 360°	A-axis 360°
Spindle	High-frequency spindle	High-frequency spindle
Maximum speed / spindle power	100.000 rpm 860 watt	100.000 rpm 860 watt
Tools	Milling and grinding tools with 3 mm tool shaft	Milling and grinding tools with 3 mm tool shaft
Tool changer	6-fold	10-fold
Tool length control	≤ 0.002 mm precision	≤ 0.002 mm precision
Integrated PC	Windows based	Windows based
Display	Integrated 10"1" touchscreen	Integrated 10"1" touchscreen
Illumination	Dynamic LED illumination	Dynamic LED illumination
Software	SmartControl™ integrated CNC software	SmartControl™ integrated CNC software
Air pressure	No external air pressure needed	No external air pressure needed
Cooling liquid	3 liter/11.36 gpm integrated	3 liter/11.36 gpm integrated
Connecting requirements		
Weight	77 kg / 169.8 lbs	77 kg / 169.8 lbs
Width x depth x height	16.6 x 21.9 x 25.4 inch / 422 x 556 x 644 mm	16.6 x 21.9 x 25.4 inch / 422 x 556 x 644 mm
Line voltage / frequency / maximum power	100 V - 230 V / 50/60 Hz / 500 watt	100 V - 240 V / 50/60 Hz / 500 watt

Sales and support partner worldwide



Represented for you in over 100 countries.

imes-icore® GmbH has been a leading manufacturer and technology partner since 2003 in the field of dental CAD/CAM systems and solutions.

With its unique range of dental milling and grinding systems imes-icore® offers a perfect selection for all individual requirements of dental laboratories, milling centres and dental practices of all sizes.

Our Open-System product philosophy makes it possible to easily integrate our milling machines into your existing workflow and to integrate them with your open scanners and your CAD/CAM software. We are open for your material selection.



Official importeur | distributeur Nederland

uberVo

DENTAL B.V.

imes-icore® Nederland